

1 2 3 4 5 6 7 8

A
B
C
D
E
F

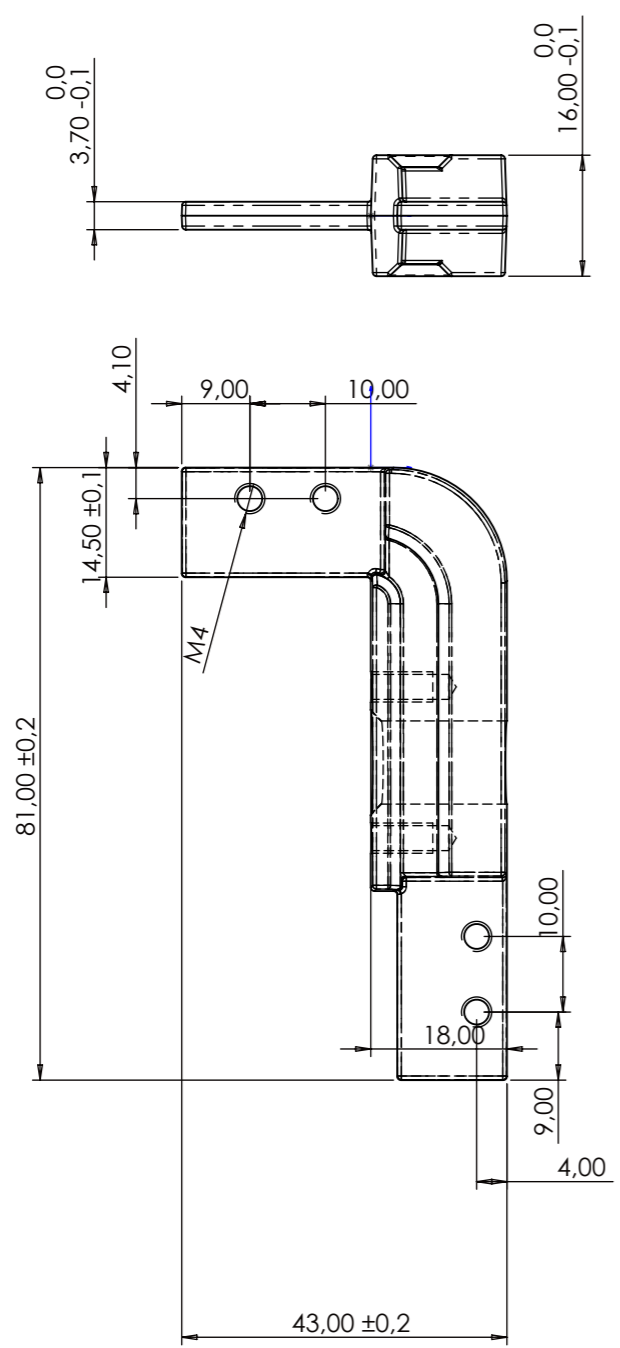

仅供报价

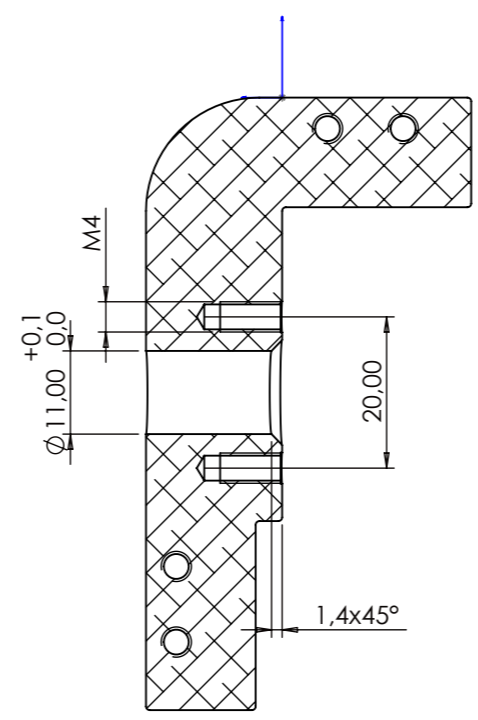
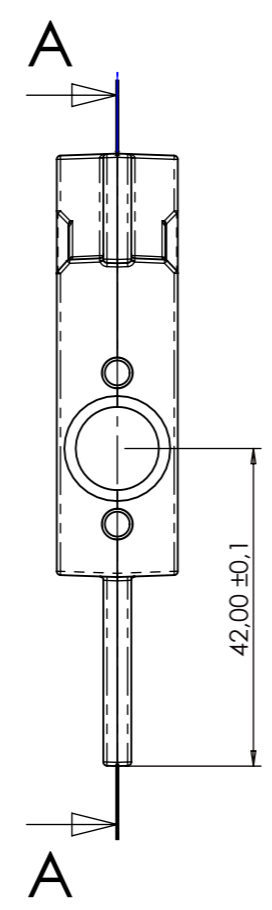

SEZIONE A-A

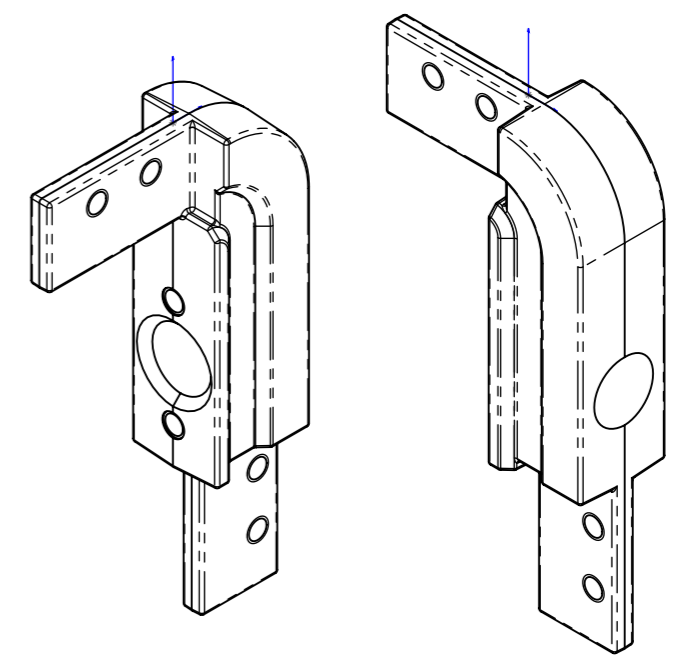

尺寸单位为毫米

Data:		28/12/16		Disegno		21A 01-16		Edizione		0	
Pagina -	N° Pag. -	Sostituisce dis. del 00-00-00		N° Pezzi -							
Scala: 1:1		Descrizione: Squadra con foro per fulcro						Misure in mm			
Disegnato: G. Daniele								Quote senza toll. grado di prec. medio UNI 22768			
Approvato								重量			
Mat Aluminium forging		材料: 铝锻造		Volume - cc		Peso: 45 gr					
Trattamenti -											

1 2 3 4 5 6 7 8