

UNLESS OTHERWISE SPECIFIED USE THE FOLLOWING:-			REV. NO.	TITLE
APPLIED PRACTICES SI-10025-SEC 2	SURFACES ✓	TOLERANCES ON MACHINED DIMENSIONS FRACTIONS ± DECIMALS ± ANGLES ±	CONT ON SHEET	SH NO.

TITLE
ROTOR YOKE FORGING
FIRST MADE FOR GMG-186-A2 GMG-187-A2 72880

FCF 41B537515
41C636573

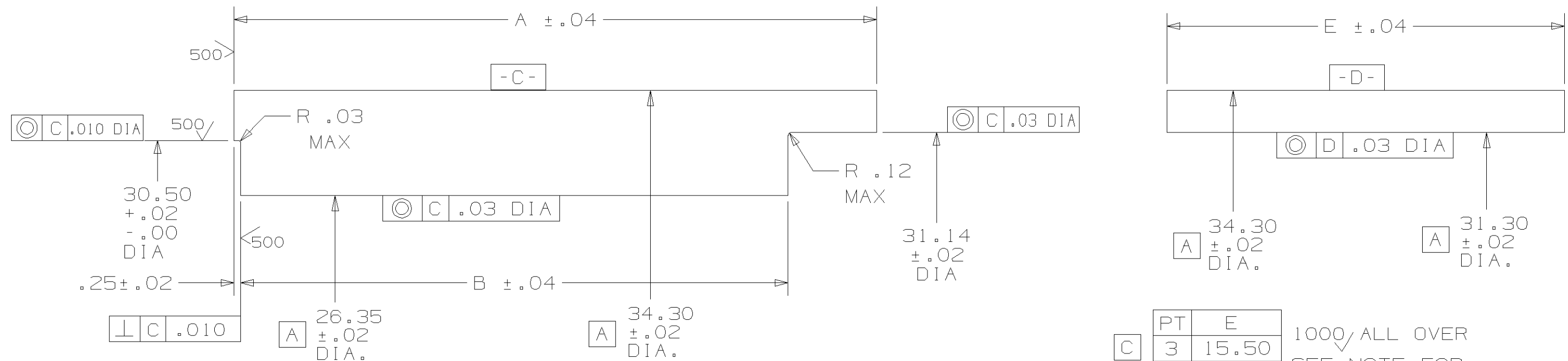

C	PT	E	1000√ ALL OVER SEE NOTE FOR MATERIAL
	3	15.50	
	6	17.00	

PT	A	B	MODEL
1	25.05	21.35	GMG-186
2	28.05	24.35	GMG-187
4	20.05	16.35	GMG-191
5	23.05	19.35	GMG-192

UG NOTE: UG 3D MODEL EXIST FOR P1, P2, P4 & P5

1000√ EXCEPT AS SHOWN
SEE NOTE FOR MATERIAL

NOTE: UG 3D MODEL EXIST FOR P3 & P6

PT.	MAKE FROM	
7	41B537513P1	SEE NOTE #1
8	41B537513P2	SEE NOTE #1
9	41B537513P4	SEE NOTE #1
10	41B537513P5	SEE NOTE #1

UG NOTE: UG 3D MODEL EXIST FOR P7, P8, P9 & P10

NOTE #1 :
"SHOT BLAST TO REMOVE OIL, DIRT, GREASE, PAINT, VARNISH AND SCALE"

MATERIAL:
B4C5A2 STL EXCEPT .33-.38 CARBON
63000 P.S.I. MIN TENSILE
42000 P.S.I. MIN YIELD
TEST TO BE MADE FROM A HAMMERED TEST BAR.

PURCHASE FROM:
EDGEWATER STEEL CO.
PITTSBURGH, PA.
OR EQUIV.

PART OR GROUP	CURRENT REVISION
P10	G
P9	G
P8	G
P7	G
P6	E
P5	D
P4	D
P3	D
P2	D
P1	D

REVISIONS				PRINTS TO	
G	02/15/03	N.KUMAR C.FOX	CO-081483 REV ONLY	6012	
B	JULY 6, 1989	K.MARSDEN	-2		
C	MAY 15, 1990	D.GARVIN	-3		
D	SEPT 18, 1992	D.GARVIN	-4		
E	APRIL 20, 1994	WELSER.DL	20080 ADD P6		
F	01/22/03	YOGANAND B.TOLON	CO-078255 ADD UG NOTE		

PLOT SCALE .25

REF 41C636204

MADE BY DAN WELSER JUN 15, 1983	ISSUED DAN WELSER JUN 21, 1983	APPROVALS JJG 6-16-83 JJM	TSD	DIV OR DEPT	41B537513
UGPROP B CONVERTED			ACIAG	RY	CONT ON SHEET F SH. NO. 1