

MACHINING NOTES:

1. DEBURR MACHINED SHARP EDGES: 0.2 MAX X 0.2 MAX
2. MACHINED INTERNAL CORNER RADII: R0.2mm MAX UOS
3. MACHINED EXTERNAL CORNER RADII: R0.2mm MAX UOS

INSPECTION NOTES:

1. DIMENSIONS AND GEOMETRIC TOLERANCES MARKED * TO BE 100% INSPECTED AND INSPECTION REPORT PROVIDED

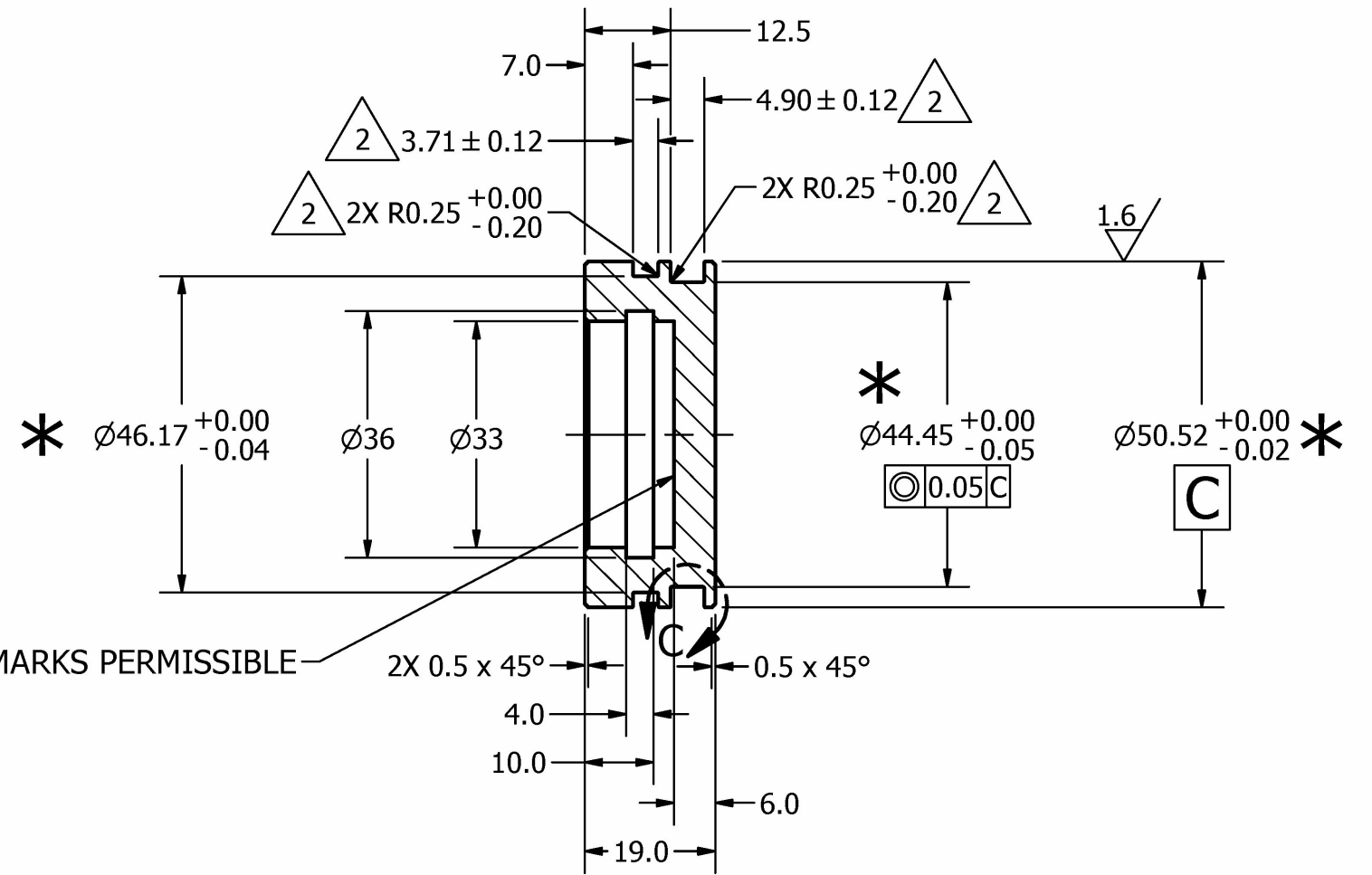

TOOL MARKS PERMISSIBLE

SECTION A-A

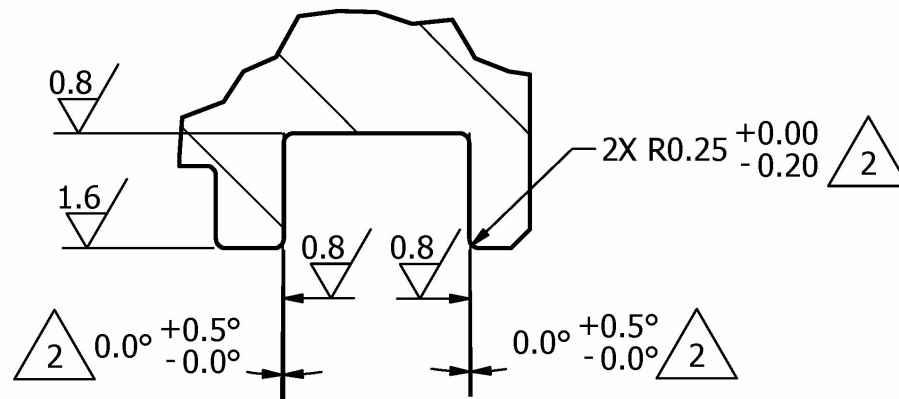
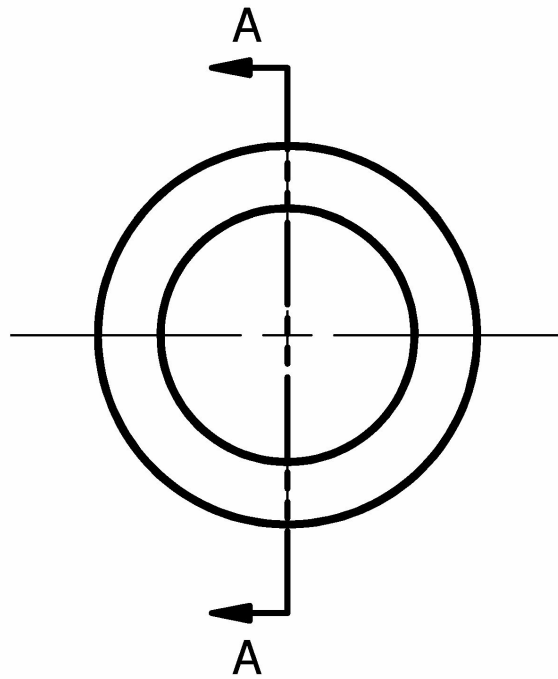

DETAIL C
SCALE 5 : 1
(TYP 2 PL)

2	GROOVE DIMS AND MATERIAL DESCRIPTION MOD	MOD	1112	RmCd	JL	MJ	17/10/2014
1	RELEASED FOR MANUFACTURE	JL	1098	MOD	JL	MJ	27/08/2014
REV	DESCRIPTION	DRN	CN	CHK	ENG	APP	DATE

**REFERENCE PURPOSES ONLY
NOT TO BE USED
FOR MANUFACTURE**

TOLERANCE UNLESS SPECIFIED OTHERWISE:-
0 PLACES ±1.0 1 PLACE ±0.25
2 PLACES ±0.15 ANGLE ±0.5°
SURFACE FINISH 3.2 Ra
INTERPRET DIMENSIONS AND TOLERANCES PER ASME Y14.5-1994

TITLE							
DIMENSIONS IN MM UNLESS OTHERWISE STATED							
DRAWN	JL	DATE	21/07/14	MATERIAL CARBON STEEL - AS1443 / M1020			
CHKD		DATE		DRG NO 25-2025-2			
ENG		DATE		SCALE 1:1 SHEET NO - 1 OF 1 A3			
APP		DATE					